

**CONSULTANCY SERVICES FOR PREPARATION OF  
DETAILED PROJECT REPORT (DPR)  
INCORPORATING DETAILED ENGINEERING DESIGN,  
WORKING DRAWINGS AND TENDER DOCUMENTS INCLUDING  
TENDER DRAWINGS, TENDER BOQ ETC. FOR  
CONSTRUCTION OF R.C.C BRIDGE OVER RIVER  
KALNAGINI AT GHATIHARA  
UNDER KAKDWIP BLOCK IN THE DISTRICT OF  
SOUTH 24 PARAGANAS**

## **RFP DOCUMENTS**

**NIRFP No. HRBC/PL & DN/05 of 2014 – 2015 (2<sup>nd</sup> Call),**

**Dated: 04.08.2014**

### **HOOGHLY RIVER BRIDGE COMMISSIONERS**

**(A Statutory Organisation under Government of West Bengal)**

**TRANSPORT DEPARTMENT**

**MUNSHI PREMCHAND SARANI**

**(ST. GEORGE'S GATE ROAD)**

**KOLKATA – 700 021**

**AUGUST 2014**

**CONSULTANCY SERVICES FOR PREPARATION OF  
DETAILED PROJECT REPORT (DPR)  
INCORPORATING DETAILED ENGINEERING DESIGN,  
WORKING DRAWINGS AND TENDER DOCUMENTS INCLUDING  
TENDER DRAWINGS, TENDER BOQ ETC. FOR  
CONSTRUCTION OF R.C.C BRIDGE OVER RIVER KALNAGINI  
AT GHATHARA UNDER KAKDWIP BLOCK  
IN THE DISTRICT OF SOUTH 24 PARAGANAS**

**RFP DOCUMENTS**

**HOOGLY RIVER BRIDGE COMMISSIONERS**

(A Statutory Organisation under Government of West Bengal)

**TRANSPORT DEPARTMENT  
MUNSHI PREMCHAND SARANI  
(ST. GEORGE'S GATE ROAD)  
KOLKATA – 700 021**

**AUGUST 2014**

# **RFP DOCUMENTS**

**FOR**

**CONSULTANCY SERVICES FOR PREPARATION OF  
DETAILED PROJECT REPORT (DPR)  
INCORPORATING DETAILED ENGINEERING DESIGN,  
WORKING DRAWINGS AND TENDER DOCUMENTS INCLUDING  
TENDER DRAWINGS, TENDER BOQ ETC. FOR  
CONSTRUCTION OF R.C.C BRIDGE OVER RIVER KALNAGINI  
AT GHATHARA UNDER KAKDWIP BLOCK  
IN THE DISTRICT OF SOUTH 24 PARAGANAS**

## **CONTENTS**

### **Volume I**

**Section 1** Notice Inviting Request For Proposal (NIRFP)

**Section 2** Instructions to Bidders

**Section 3**

Section 3A Form of Bid,

Section 3B Form of Agreement

Section 3C Form of Bank Guarantee for Performance Security

Section 3D Undertaking for Not Blacklisted

Section 3E Undertaking for Technical Manpower Deployment

Section 3G Form of Bid Security (Bank Guarantee)

**Section 4** General Conditions of Contract

**Volume II** Financial Offer with Payment Schedule

**Volume III** Drawing

**CONSULTANCY SERVICES FOR PREPARATION OF  
DETAILED PROJECT REPORT (DPR)  
INCORPORATING DETAILED ENGINEERING DESIGN,  
WORKING DRAWINGS AND TENDER DOCUMENTS INCLUDING  
TENDER DRAWINGS, TENDER BOQ ETC. FOR  
CONSTRUCTION OF R.C.C BRIDGE OVER RIVER KALNAGINI  
AT GHATIHARA UNDER KAKDWIP BLOCK  
IN THE DISTRICT OF SOUTH 24 PARAGANAS**

**RFP DOCUMENTS**

**VOLUME I**

**(SECTION 1 TO 4)**

**HOOGLHY RIVER BRIDGE COMMISSIONERS**

**(A Statutory Organisation under Government of West Bengal)**

**TRANSPORT DEPARTMENT**

**MUNSHI PREMCHAND SARANI**

**(ST. GEORGE'S GATE ROAD)**

**KOLKATA – 700 021**

**AUGUST 2014**

**VOL. I - SECTION 1**  
**NOTICE INVITING REQUEST FOR PROPOSAL**  
**(NIRFP)**

# HOOGHLY RIVER BRIDGE COMMISSIONERS

HRBC BHAWAN, ST. GEORGES' GATE ROAD

KOLKATA-700 021

## NOTICE INVITING REQUEST FOR PROPOSAL (NIRFP)

NIRFP No. HRBC/PL & DN/05 of 2014 – 2015 (2<sup>nd</sup> Call), Dated: 04.08.2014

1. Hooghly River Bridge Commissioners (HRBC) invites sealed proposals on single stage two packet system from experienced and reputed Consulting firms to provide Consultancy Services for Construction of Concrete Bridge including viaducts in Sundarban Region as enumerated in the Name of Work below.
2. Name of work: Providing Consultancy Services for Preparation of Detailed Project Report (DPR) incorporating Detailed Engineering Design, working drawings and Tender Documents including tender drawings, tender BOQ etc. for 'Construction of R.C.C Bridge over River Kalnagini at Ghatihara under Kakdwip Block in the district of South 24 Paraganas'.
3. Particulars of bridge: Indicative length of Main Bridge (excluding viaduct) is 102.00 mtr.
4. Bid Security: Rs. 1.0 lac
5. Cost of RFP document: Rs.5,000/-
6. Period of Contract: 4 (four) months.
7. RFP documents: Request for Proposal document consisting of detail scope of work, project details, eligibility criteria etc. can be downloaded from the website of HRBC i.e. **www.hrbc.in** from **05.08.2014**. The bidder shall have to pay the cost of RFP document as shown in para 5 along with the offer at the time of submission of RFP document.
8. Receipt of proposal: All sealed proposals containing Packet-1 and Packet-2 duly filled in a outer sealed cover should be dropped in the Tender Box kept in the chamber of Director (Pl. & Dn.), HRBC not later than **14.00 hrs. on 07.08.2014** and bid (Packet-1) will be opened on the same day at **14.30 hrs.** in presence of Consultants representatives who choose to attend.
9. RFP document containing eligibility and qualification criteria in **Packet 1** will be opened first and evaluated. The Consulting firms will be selected based on fulfilling the prescribed qualification & eligibility criteria.

Financial proposal in **Packet 2** in respect of selected Consulting firms only will be opened for evaluation of financial offers for which date and time will be communicated to the qualified bidders.

**Bidder's Signature and Stamp**

10. For any queries and clarification, interested Consultants may visit the site and may contact the Director (Pl. & Dn.) at the address mentioned at para 11 below.
11. Address for Communication:
- Director (Planning & Design)  
Hooghly River Bridge Commissioners  
HRBC BHAWAN – 3<sup>rd</sup> Floor  
St. Georges Gate Road, Kolkata – 700 021  
Ph. No.- 2253-4133, Fax No.- 033-2248-5833  
Email: direc.pldn@gmail.com
12. Interested Consulting firms may consult the HRBC website mentioned above regularly to see Corrigenda/Addenda which may be issued by HRBC from time to time prior to submission of the proposal as given in para 8.
13. The agencies, who have submitted their documents earlier in the previous NIRFP vide no. HRBC/PL & DN/04 of 2014-2015, dt. 31.07.2014, need not submit bid security further in this NIRFP. However, they have to submit Cost of RFP document as well as all documents in support of their eligibility in this NIRFP.
14. HRBC reserves the right to accept/reject any or all proposals without assigning any reason thereof.

**Director (Pl & Dn)**  
**Hooghly River Bridge Commissioners**

**VOL. I - SECTION 2**  
**INSTRUCTIONS TO BIDDERS**



## **VOL. I SECTION 2. INSTRUCTIONS TO BIDDERS**

### **Table of Clauses**

#### **A. General**

1. Scope of Bid
2. Eligible Bidders
3. Qualification of the Bidder
4. Participation in Bids
5. Cost of Bidding
6. Site Visit

#### **B. RFP Documents**

7. Content of RFP Documents
8. Clarification of RFP Documents
9. Amendment of RFP Documents

#### **C. Preparation of Bids**

10. Language of Bids
11. Documents comprising the Bid - Deleted
12. Bid Prices
13. Currencies of Bid and Payment
14. Bid Validity
15. Bid Security
16. Pre-Bid Meeting
17. Format and Signing of Bid

#### **D. Submission of Bids**

18. Sealing and Marking of Bids
19. Deadline for Submission of Bids
20. Late Bids
21. Modification and Withdrawal of Bids

#### **E. Bid Opening and Evaluation**

22. Bid Opening
23. Process to be Confidential
24. Clarification of Bids / Breakdown of rates
25. Examination of Bids and Determination of Responsiveness
26. Correction of Errors
27. Evaluation and Comparison of Bids

#### **F. Award of Contract**

28. Award
29. Employer's Right to Accept any Bid and to Reject any of all Bids
30. Notification of Award
31. Signing of Agreement
32. Performance Security/Guarantee
33. Annulment of the Award
34. Issue of Notice to Commence

**Bidder's Signature and Stamp**

## **VOL. I SECTION 2. INSTRUCTIONS TO BIDDERS**

### **A. GENERAL**

#### **1 Scope of Bid:**

##### **1.1 Project Background**

Hooghly River Bridge Commissioners (HRBC) under Transport Department, Govt. of West Bengal proposes to undertake the construction of the Proposed R.C.C. Bridge in Sunderban Region in the district of South 24 Parganas, West Bengal, India under Sunderban Development Board. With a view to improve the road connectivity and transportation facility, Department of Sunderban Affairs, Govt. of West Bengal has decided to construct bridges and selected Hooghly River Bridge Commissioners (HRBC) as the implementing agency.

HRBC invites request for proposal on single stage two packet system from experienced and reputed Consulting firms to provide Consultancy Services for Preparation of Detailed Project Report (DPR) incorporating Detailed Engineering Design, working drawings and Tender Documents including tender drawings, tender BOQ etc. as specified below for construction of R.C.C Bridge over River Kalnagini at Ghatihara under Kakdwip Block in the district of South 24 Paraganas.

The proposed bridge over river Kalnagini is located at Ghatihara under Kakdwip Block in the district of South 24 Parganas. The indicative length of main bridge is around 102.0 mtr. excluding viaduct.

Thus, the proposed bridge would benefit the people living in those isolated areas immensely as they would not have to depend on the ferry service.

##### **1.2 Scope of work:**

1.2.1 The scope of the work under these terms of reference would consist of – but not limited to the provisions laid down below. The Consultancy firm shall provide comprehensive planning and design services in respect of the work for construction of the bridge and other ancillary works, which are given as below:

- i. Preliminary Engineering :
  - a) Analysis/evaluation of Site data collected, viz; detail engineering survey and sub-soil investigation report (to be supplied by HRBC) with regard to Discharge H.F.L afflux, waterway width, horizontal and vertical clearance, span arrangement, foundation and superstructure etc.
  - b) Techno-economic and socio-economic evaluation of alternative proposals and Finalization of concept and structural system
  - c) Preparation of General Arrangement Drawing (GAD), detailed Hydrological Report and Span arrangement for the purpose of vetting from I & W Department, Govt. of W.B.

- ii. Detailed Engineering :
  - a) Preparation of detailed design along with working drawings.
  - b) Preparation of Detailed cost estimate on basis of latest Schedule of Rates of P.W(Roads) / P.W(NH Wing) / P.W.D., West Bengal including quantity calculation and rate analysis.
  - c) Preparation of Technical Specification, Bill of Quantities and tender drawings.
  - d) Preparation of Detailed Project Report (DPR).

The Detailed Project Report contains the following:

### **Volume I - Main Report**

The detailed Report including the cost estimate of the bridge is presented in this volume along with all supporting calculations. The discharge calculation, the sub-soil investigation report, rate analysis, quantities calculations etc. are included as an annexure to this report.

### **Volume II – Detailed Design and Drawing Volume**

This volume includes the drawings for the following:

- A. Detailed design calculations including computer analysis input and output data
- B. Detailed Working drawings consisting of
  - (i) Location map with index plan
  - (ii) Cross-sections of the river at various sections.
  - (iii) Detailed working drawings for bridge, viaduct and approach road.

On preparation of the DPR, detailed discussion shall be held with the Director (Pl. & Dn.), HRBC, Chief Project Manager, HRBC and the Vice-Chairman, HRBC before the DPR is finalized and submitted.

- iii. The proposed structure should be aesthetically compatible with the river bank roads and also to the surrounding.
- iv. The consultant shall be responsible for arranging vetting of GAD from I & W Dept. in compliance with prevailing Rules and Regulations etc.
- v. All specialized works shall be done through professional experts to be employed by the Consultancy Firm.
- vi. The consultancy firm should have permanent running establishment in Kolkata.
- vii. The Consultant shall submit all the reports and drawings in 8 (eight) sets of hard copies and 2 (two) sets of soft copies in the form of CD. However, the design calculations shall be submitted in 4 (four) sets of hard copies and 2 (two) sets of soft copies in the form of CD.

- viii. All contract drawings along with tender specification and Bill of Quantities (BOQ) shall have to be furnished within 6 (six) weeks and all the working drawings shall be furnished in the remaining period.
- ix. The Consultant will also carry out modifications in design notes and drawings based on revised soil parameters, defective piles etc. as generated during construction.

1.2.2 Since this is a time bound project, no time overrun is acceptable. The bidder should submit a phase wise work plan mentioning their schedule of providing their services in respect of different items of work.

### 1.2.3 **Structural Design**

While preparing the report for this project the principle as laid down in "Manual for Survey, Investigation and Preparation of Road Projects" published by Indian Road Congress (Latest Edition) should be followed as the guideline, as shall be applicable to this particular assignment.

In designing the bridge and preparation of drawings, some obligatory parameters are to be followed. Bids, which do not adhere to the following parameters, are liable to be held as non-responsive and rejected. These parameters are:

- a) All designs shall be done according to relevant latest guidelines/circulars of MORTH and IRC/BIS design codes unless otherwise desired by the Engineer. The structural analysis and design shall be done by using latest version of software packages such as STAADPRO or equivalent.
- b) The loading shall be IRC 2-Lanes of Class A.
- c) The bridge will have concrete piers founded on bored piles & concrete pier caps, PSC Girder with concrete deck slab and R.C.C. parapet.
- d) The width of carriageway shall be minimum 5.50 M and provision shall be kept for 1.0 M wide footpath on either side of the carriageway. However, the width of carriageway shall be finalized after studying the socio-economic condition of the broad influence area and the future scope of development of the areas connected by the proposed bridge.

1.2.4 The consultant shall supply all design calculations/computer input and output giving specific reference to IRC/MORTH and all drawings (structural & others) in hard copies as well as in soft copies in requisite numbers. All soft copies of the drawings shall be submitted in PDF as well as AutoCAD format for subsequent modification/revisions to be made on "As-built drawings" to be prepared in later stage.

1.2.5 Structural design calculations and drawings shall be vetted by a Proof Consultant. The bidder shall appoint leading Institution like an IIT or Jadavpur University, Kolkata or Indian Institute of Engineering Science and Technology, Shibpur, Howrah (Formerly, BESU, Shibpur) as Proof Consultant in consultation with HRBC and a copy of the appointment letter of Proof Consultant shall be submitted to HRBC. The bidder shall make payment to Proof Consultant for rendering their services. The Consultant will interact with the Proof Consultant during the checking process and provide clarifications and submit modified calculations and drawings as may be necessary.

### 1.2.6 **Construction Stage**

During construction of the project, the consultant may be asked to visit the site for any clarifications/modifications/suggestions etc. and for consequent revision of working drawings arising from site requirement. For revision/ modification of working drawings, no charges shall be paid by the Employer.

### 1.2.7 **Time for completion**

The successful bidder shall complete the works within 4 (four) months from the date of issue of the Letter of Acceptance subject to compliance of provision in Clause 2.2 of Section 4, General Condition of Contract.

For preparation of revised drawing as per necessity of works at site suitable time extension may be given to the consultant for completion of entire work.

### 1.2.8 **Deliverables and Timelines**

<b>Stage</b>	<b>Delivering of Services</b>	<b>Timeline</b>
1	<ul style="list-style-type: none"> <li>• Preparation of alternative proposals for finalization of concept and structural system as detailed in the RFP doc. and submission for approval of the same by the authority.</li> <li>• Preparation and submission of GAD along with Hydrological Report to I &amp; W Dept for vetting as per their rules and after obtaining approval, submission of the approved documents in original to the client.</li> <li>• Preparation and submission of Preliminary Project Report with preliminary project estimate.</li> </ul>	By the end of week 3
2	<ul style="list-style-type: none"> <li>• Preparation and submission of detailed cost estimate including quantity calculation and rate analysis, technical specification, bill of quantities and tender drawings. etc. based on approved drawings.</li> </ul>	By the end of week 6
3	<ul style="list-style-type: none"> <li>• Preparation and submission of substructure drawings with design calculations upto pilecap level with all details after obtaining vetting from the Proof Consultant.</li> </ul>	By the end of week 8
4	<ul style="list-style-type: none"> <li>• Preparation and submission of substructure drawings with design calculations from pilecap level to pier cap/ abutment cap with all details after obtaining vetting from the Proof Consultant.</li> </ul>	By the end of week 10
5	<ul style="list-style-type: none"> <li>• Preparation and submission of superstructure (including viaduct, if any) drawings with design calculations above pier cap/ abutment cap with all details after obtaining vetting from the Proof Consultant.</li> </ul>	By the end of week 14

**Bidder's Signature and Stamp**

Stage	Delivering of Services	Timeline
6	<ul style="list-style-type: none"> <li>• Preparation and submission of Miscellaneous working drawings with design calculations in respect to following works.                             <ol style="list-style-type: none"> <li>1. Bearings</li> <li>2. Expansion Joints</li> <li>3. Approach road</li> <li>4. Parapet, Drainage Spout, Wearing coat, Handrails etc.</li> </ol> </li> </ul>	By the end of week 15
7	<ul style="list-style-type: none"> <li>• Preparation and submission of Detailed Project Report (DPR).</li> </ul>	By the end of week 16
8	<ul style="list-style-type: none"> <li>• On compliance of modifying and revising structural / working drawings or for any other specific requirement relating to services of the consultant.</li> <li>• On completion of the scope of work as provided in the contract to the satisfaction of the client.</li> </ul>	By the end of 4 months

## 2. Eligible Bidder

- 2.1 The proposals for this contract will be considered only from those bidders (proprietorship firms, partnership firms, companies, corporations, consortia or joint ventures) who meet requisite eligibility criteria subject to complying with the provisions in Clause 2.2 and Clause 3.
- 2.2 Bidder must not have been blacklisted or deregistered by any central/state government department or public sector undertaking. Also no work of the bidder must have been rescinded by client after award of contract during last 5 years. The bidder should submit undertaking to this effect in proforma as given in Vol. I, Section 3D.
- 2.3 Joint Venture Company or the Consortium must not have more than two members. While submitting proposal an MOU or a copy of agreement in the name of proposed company has to be attached with all particulars of the respective partners for evaluation of eligibility criteria. Earnest Money is to be deposited in the name of the proposed company or in the name of lead partner. Legal and valid agreements between the partners of Joint Venture Company/Consortium will be made indicating lead partner and the duties and responsibility of each of the partner shall be specifically included in the agreement. Copy of the said agreement duly self attested shall be submitted before execution of agreement. Capabilities of both partners will be combined to evaluate the eligibility of the Joint Venture Company.
- 2.4 The bidder should submit a written power of attorney authorizing the signatory of the bid to commit the bidder.

**Bidder's Signature and Stamp**

### 3. Qualification of the Bidder

#### - Eligibility and Qualification Criteria

#### 3.1 Consultancy Experience:

- a) The consultant should have the experience in planning and detail design of RCC/ PSC bridge over river. The consultant must have completed detailed planning and structural designs of R.C.C./ PSC bridge over river for total bridge length (excluding viaduct) of 100.0 M or more during the last 10 years prior to the date of application.

Experience of completed projects shall be submitted in the following format:

Sl. No.	Name of the project	Name & address of Client with Telephone No.	Detail of the project, Total bridge length, Cost of project etc.	Cost of consultancy (in Rs.)	Date of start & completion of the consultancy services

Completion certificates and documentary evidences with photographs, duly self attested, should be attached in support of the above submission.

#### 3.2 Financial Capacity:

- a) The bidder should have minimum average annual turnover during last 3 (three) years ending on 31<sup>st</sup> March, 2014 in the work of consultancy services only to the tune of Rs. 1.5 crores.
- b) The firm should be profit making and shall submit audited balance sheet, profit & loss account and statement of turnover for the last 3 (three) years (2011-12, 2012-13 & 2013-14) **duly certified by Chartered Accountant.**

The particulars of Annual Turnover may be submitted in the following format:

Sl. No.	Year	Turn Over in (Rs. Crore)	Details of attachments (Certified by C.A.)
1.	2011-2012		
2.	2012-2013		
3.	2013-2014		

#### 3.3 Technical Manpower Deployment:

- a) The consultant must give undertaking that they will deploy the following key personnel for carrying out the consultancy services in connection with the project if the contract is awarded to them eventually. The key technical personnel must be on their regular roll of the firm/consultancy for at least one year prior to the date of bid submission.

Besides, the consultancy firm will also undertake to deploy non-technical manpower and provide adequate design and drafting facilities including software. The bidder should submit undertaking for technical manpower deployment as per format given in Vol. I, Section 3E.

**Note:** The CV of the above key personnel should be submitted signed by the key personnel and counter signed by the bidder. The CV should give all details in order to satisfy the requirements mentioned above.

#### 3.4 **General Criteria :**

- i) The company should furnish self attested copies of PAN Card and Service Tax Registration Certificate.
- ii) Partnership deed/Memorandum and AOA of the firm and their details should be furnished.

#### **4. Participation in Bids**

4.1 Bidder shall submit only one bid either by himself, or as a partner in a joint venture. A bidder who submits or participates in more than one bid shall be disqualified.

#### **5. Cost of Bidding**

5.1 The bidder shall bear all costs associated with the preparation and submission of his bid and the Employer will in no case be responsible or liable for those costs.

#### **6. Site Visit**

6.1 The bidder is advised to visit and examine the Site of Works and its surroundings and obtain for himself on his own responsibility all information and data for preparing the bid and entering into a contract for the captioned works. The costs of visiting the Site and collection of information and data shall be at the bidder's own expense.

6.2 The Employer may conduct a Site visit, if necessary.

### **B. RFP Documents**

#### **7. Content of RFP Documents**

7.1 The RFP documents are those stated below, and should be read in conjunction with any Addenda, if any, issued in accordance with Clause 9.

1. Notice Inviting RFP
2. Instructions to Bidders
3. General Conditions of Contract
4. Financial Offer with Payment Schedule

**Bidder's Signature and Stamp**



5. Forms of Bid and Bid Security
6. Form of Agreement
7. Form of Bank Guarantee for Performance Security
8. Form of Bank Guarantee for Bid Security
9. Undertaking for Technical Manpower Deployment
10. Undertaking for Not Blacklisted
11. Drawing

7.2 The bidder is expected to examine carefully the contents of the RFP documents. Failure to comply with the requirements of bid submission will be at the bidder's own risk. Pursuant to Clause 25, bids which as per opinion of the employer are not substantially responsive to the requirements of the bid RFP documents will be rejected.

## **8. Clarification of RFP Documents**

8.1 A prospective bidder requiring any clarification of the RFP documents may contact the office of HRBC and get their issues clarified.

## **9. Amendment of RFP Documents**

9.1 At any time prior to the deadline for submission of bids, the Employer may, for any reason, whether at his own initiative or in response to a clarification requested by a prospective bidder, modify the RFP documents by issuing addenda.

9.2 Any addendum thus issued shall be part of the RFP documents pursuant to Sub-Clause 9.1, and shall be communicated in writing or by cable or through website to all purchasers of the RFP documents. Prospective bidders shall acknowledge receipt of each addendum by writing or through e-mail by cable to the Employer.

## **C. Preparation of Bids**

### **10. Language of Bid**

10.1 The RFP shall be prepared in English language. All the documents related to bids supplied by the bidder should also be in English language.

### **11. Documents comprising the Bids**

Deleted

### **12. Bid Prices**

12.1 Unless slated otherwise in the RFP documents, the Contract shall be for the whole Works as described in Sub-Clause 1.2, based on the lump sum consultancy fees submitted by the bidder. The accepted bid shall be the finally arrived contract price.

**Bidder's Signature and Stamp**

- 12.2 All duties, taxes and other levies as also payment of fees for vetting to proof consultant payable by the Consultant under the Contract, or for any other cause, shall be included in the lump sum consultancy fees to be quoted by the bidder, and the evaluation and comparison of bids by the Employer shall be made accordingly. HRBC will not make any payments towards taxes, levies, etc. or any other kind of taxes.
- 12.3 The lump sum consultancy fees quoted by the bidder are FIRM for the entire contract period including extensions.

### **13. Currencies of Bid and Payment**

- 13.1 The lump sum consultancy fees shall be quoted by the bidder entirely in Indian Rupees.

### **14. Bid Validity**

- 14.1 Bids shall remain valid for a period of 120 (one hundred and twenty) days after the date of Bid opening specified in Clause 22.
- 14.2 In exceptional circumstances, prior to expiry of the original bid validity period, the Employer may request that the bidders extend the period of validity for a specified additional period. The request and the responses thereto shall be made in writing or by cable. A bidder may refuse the request without forfeiting the bid security. A bidder agreeing to the request will not be required or permitted to modify his bid, but will be required to extend the validity of his bid security for the period of extension, and in compliance with Clause 15 in all respects.

### **15. Bid Security**

- 15.1 The bidder shall furnish, as part of his bid, a bid security in the amount of Rs.1.0 lac (Rupees one lac only).
- 15.2 The bid security shall be furnished in the form of Demand Draft drawn on Nationalized Bank or Scheduled Bank in India to be acceptable to HRBC in favour of 'Hooghly River Bridge Commissioners', payable at Kolkata.
- The bid security may also be paid in the form of unconditional and irrevocable Bank Guarantee in favour of HRBC from a Nationalised or Scheduled Bank of India to be acceptable to the Employer. The format of the Bank Guarantee shall be in accordance with the form of bid security included in Vol.- I, Section-3 of the Tender Document. Other formats may be permitted, subject to the prior approval of the Employer.
- 15.3 Any bid not accompanied by an acceptable bid security shall be rejected outright by the Employer as non-responsive.
- 15.4 The bid securities of unsuccessful bidders will be returned as promptly as possible, after issuance of LOA.

- 15.5 The Bid security of the successful Bidder will be returned when the bidder has furnished performance security and signed the agreement.
- 15.6 The bid security may be forfeited
- (a) if the bidder withdraws his bid during the period of bid validity;
  - (b) if the bidder does not accept the correction of his bid price, pursuant to Sub-Clause 26.2 or
  - (c) in the case of a successful bidder fails within the specified time limit to
    - (i) sign the Agreement
    - (ii) furnish the required performance security

## 16. Pre-bid Meeting

There will be no pre-bid meeting.

## 17. Format and Signing of Bid

- 17.1 The bidder shall prepare only one copy of the RFP documents comprising the bid as described in Clause 7 of Instructions to Bidders.
- 17.2 The bid shall be typed or written in indelible ink and shall be signed by a person or persons duly authorized to sign on behalf of the bidder, pursuant to Sub-clauses 2.4. All pages of the bid shall be initialed by the person or persons signing the bid.
- 17.3 The bid shall contain no alterations, omissions or additions, except those to comply with instructions issued by Employer, or as necessary to correct errors made by the bidder, in which case such corrections shall be initialed by the person or persons signing the bid.

## D. Submission of Bids

## 18. Sealing and Marking of Bids

- 18.1 The bidder shall seal Technical and Financial proposals in two separate envelopes. The envelopes are to be marked as Packet 1: 'TECHNICAL BID' and Packet 2: 'FINANCIAL BID' respectively.

### **The Packet 1 envelope should contain:**

1. Particulars relating to Qualification of Bidder – Eligibility and Qualification Criteria as per Clause 3 of Instructions to Bidder.
2. Self attested copies of PAN CARD and Service Tax Registration Certificate.
3. Bid security of Rs.1.0 lac in the form of Demand Draft or Bank Guarantee.
4. Cost of RFP Document of Rs. 5,000/- in the form of Demand Draft.
5. A written of Power of Attorney authorizing the signatory of the bid.
6. Undertaking for technical manpower deployment as per Vol I Section 3E.
7. Undertaking for not blacklisted as per Vol I Section 3D

**Bidder's Signature and Stamp**

**The Packet 2 envelope shall include:**

Entire original RFP document containing the Financial offer.

Both the Packet 1 and Packet 2 envelopes shall be finally sealed in a outer single envelope and shall be dropped in the Tender Box which is kept in the chamber of Director (Pl. & Dn.), HRBC.

18.2 The sealed envelope shall

- (a) be addressed to:  
Director (Pl. & Dn.)  
Hooghly River Bridge Commissioners  
HRBC Bhawan, Munshi Prem Chand Sarani  
(St. George's Gate Road), Kolkata 700 021
- (b) bear the following identification:
  - i) Name of the Work
  - ii) Name & Address of the bidder

18.3 If the envelope is not properly sealed and marked as above, the Client will assume no responsibility for the misplacement and all consequences shall rest on the bidder including rejection of the bid.

**19. Deadline for Submission of Bids**

19.1 Bids must be received by the Employer at the address specified above not later than **14.00 hrs. on 07.08.2014.**

19.2 The Employer may, at his discretion, extend the deadline for submission of bids, by issuing an addendum in accordance with Clause 9, in which case all rights and obligations of the Employer and the bidders previously subject to the original deadline will thereafter be subject to the deadline as extended.

**20. Late Bids**

20.1 Any bid received by the Employer after the deadline for submission of bids prescribed in Clause 19 will be rejected and returned unopened to the bidder by Registered Post with A/D, which shall be treated as the fulfillment of obligation by the employee.

**21. Modification and Withdrawal of Bids**

21.1 The bidder may modify or withdraw his bid after bid submission, provided that written notice of the modification or withdrawal is received by the Employer prior to the deadline for submission of bids and is approved and consented by the Employer.

- 21.2 The bidder's modification or withdrawal notice shall be prepared, sealed, marked and delivered in accordance with the provisions of Clause 18, with the outer and inner envelopes additionally marked "MODIFICATION" or "WITHDRAWAL" as appropriate.
- 21.3 No bid may be modified by the bidder after the deadline for submission of bids.
- 21.4 Withdrawal of a bid during the interval between the deadline for submission of bids and the expiration of the period of bid validity specified in the Form of Bid may result in the forfeiture of the bid security pursuant to Clause 15.

## **E. Bid Opening and Evaluation**

### **22 Bid Opening**

- 22.1 The Employer or his authorized representative will open the envelope containing the proposal, including withdrawals and modifications made pursuant to Clause 21, in the presence of bidder's representatives who choose to attend, at **14.30 hrs. on 07.08.2014** at the chamber of Director (Pl & Dn), Hooghly River Bridge Commissioners, Munshi Prem Chand Sarani (St. George's Gate Road), Kolkata 700 021, India.

RFP document containing eligibility and qualification criteria in **Packet 1 (Technical Bid)** will be opened first and evaluated. The Consulting firms will be selected based on fulfilling the prescribed qualification & eligibility criteria. Financial proposal in **Packet 2** in respect of selected Consulting firms only will be opened for evaluation of financial offers subsequently.

The bidder's authorized representatives who will be present shall sign a register evidencing their attendance.

- 22.2 Before declaration of the financial offer in Packet 2, if it is detected that one or more pages are missing in the RFP documents, which have been downloaded from HRBC website, then those pages shall be supplied by HRBC and the pages shall be attested and signed by the bidder or his authorized representative in person.

Under any circumstances the bidder shall not alter or change the financial offer.

### **23. Process to be Confidential**

- 23.1 Information relating to examination, clarification, evaluation and comparison of bids and recommendations for the award of a contract shall not be disclosed to bidders or any other persons not officially concerned with such process until the award to the successful bidder has been announced. Any effort by a bidder to influence the Employer's processing bids or award decisions may result in the rejection of the bidder's bid.

## **24. Clarification of Bids / Break down of rates**

24.1 To assist in the examination, evaluation and comparison of bids, the Employer may, at his discretion, ask any bidder for clarification of his bid, including breakdowns of unit rates. The request for clarification and the response shall be in writing or by cable, but no change in the price or substance of the bid shall be sought, offered or permitted except as required to confirm the correction of arithmetic errors discovered by the Employer in the evaluation of the bids in accordance with Clause 26.

## **25. Examination of Bids and Determination of Responsiveness**

25.1 Prior to the detailed evaluation of bids, the Employer will determine whether each bid (i) meets the eligibility criteria (ii) has been properly signed; (iii) is accompanied by the required securities; (iv) is substantially responsive to the requirements of the RFP documents; and (v) provides any clarification and/or substantiation that the Employer may require pursuant to Sub-Clause 24.1

25.2 A substantially responsive bid is one, which conforms to all the terms, conditions and specifications of the RFP documents, without material deviation or reservation. A material deviation or reservation is one (i) which affects in any substantial way the scope, quality or performance of the Works; (ii) which limits in any substantial way, inconsistent with the RFP documents, the Employer's rights or the bidder's obligations under the Contract; or (iii) whose rectification would affect unfairly the competitive position of other bidders presenting substantially responsive bids.

25.3 If a bid is not substantially responsive, it will be rejected by the Employer, and may not subsequently be made responsive by correction or withdrawal of the nonconforming deviation or reservation.

25.4 The criteria of non-responsiveness are as stated below but are not limited to them:

- i) Failure to comply with the Scope of Work given in Clause 1.2
- ii) Failure to comply with the requirements of bid submission
- iii) Failure to submit Bid Security as per Clause 15
- iv) Failure of Bid to conform to all the terms, conditions of RFP documents
- v) A bid which materially deviates from the requirements of the RFP documents or is a conditional offer
- vi) Any other reason which in the opinion of the Employer / Engineer renders the bid non-responsive.

The Employer's/Engineer's decision as to the non-responsiveness of any bid shall be final.

## **26. Correction of Errors**

- 26.1 Bids determined to be substantially responsive will be checked by the Employer for any errors. Errors will be rectified on the following basis. If there is a discrepancy between the rate in figures and words, the rate and amount in words shall prevail.
- 26.2 The amount stated in the Form of Bid will be adjusted by the Employer in accordance with the above procedure for the correction of errors and shall be considered as binding upon the bidder, If the bidder does not accept the corrected amount of his bid, his bid will be rejected, and the bid security may be forfeited in accordance with Sub-Clause 15.6(b).

## **27. Evaluation and Comparison of Bids**

- 27.1 The Employer will evaluate and compare only the bids determined to be substantially responsive in accordance with Clause 25.
- 27.2 In evaluating the bids, the Employer will determine for each bid the Evaluated Bid Price by adjusting the Bid Price as follows:
- (a) making any correction for errors pursuant to Clause 26;
  - (b) making an appropriate adjustment for any other acceptable variations, and deviations;

### **F. Award of Contract**

## **28. Award**

- 28.1 Subject to Clause 29, the Employer will award the Contract to the bidder whose bid has been determined to be substantially responsive to the bidding documents and who has offered the Lowest Evaluated Bid Price, provided that such bidder has been determined to be eligible and qualified in accordance with the provisions of Clause 3.
- 28.2 If any bidder comes out as the lowest offerer in more than one package, HRBC reserve the right to award any package to any other bidder at the lowest rate offered by the bidder for the respective packages.

## **29. Employer's Right to Accept any Bid and to Reject any or all Bids**

- 29.1 Notwithstanding Clause 28, the Employer reserves the right to accept or reject any bid, and to annul the bidding process and reject all bids, at any time prior to award of Contract, without thereby incurring any liability to the affected bidder or bidders or any obligation to inform the affected bidder or bidders of the grounds for the Employer's action.

### **30. Notification of Award**

- 30.1 Prior to expiration of the period of bid validity prescribed by the Employer, the Employer will notify the successful bidder by e-mail confirmed by registered letter that his bid has been accepted. This letter (hereinafter and in the Conditions of Contract called the "Letter of Acceptance") shall name the sum which the Employer will pay the Contractor in consideration of the execution of the Works by the Consultant as prescribed by the Contract (hereinafter and in the Conditions of Contract called "the Contract Price").
- 30.2 The notification of award will constitute the formation of the Contract.
- 30.3 Upon the furnishing by the successful bidder of a performance security, the Employer will promptly notify the other bidders that their bids have been unsuccessful.

### **31. Signing of Agreement**

- 31.1 At the same time that he notifies the successful bidder that his bid has been accepted, the Employer will send the bidder the Form of Agreement provided in the RFP documents, incorporating all agreements between the parties.
- 31.2 Within seven days of receipt of the Form of Agreement, the successful bidder shall sign the Form and return it to the Employer.

### **32. Performance Security/Guarantee**

Within seven days of receipt of the notification of award from the Employer, the successful bidder shall furnish to the Employer a performance security of an amount of 2.5% of the accepted total consultancy cost in the form of acceptable Bank Guarantee. The form of performance security provided in Section 3C of the RFP documents may be used or some other form acceptable to the Employer. Validity of Bank Guarantee shall cover entire duration of consultancy period including extended period, if any. The Bank Guarantee shall be released after satisfactory completion of assignment.

### **33. Annulment of the Award**

Failure of the successful bidder to comply with the requirements of Clauses 31 or 32 shall constitute sufficient grounds for the annulment of the award and forfeiture of the bid security.

### **34. Issue of Notice to Commence**

After receipt of Performance Security from the contractor as stipulated in Clause 32 of Instructions to Bidders or even after award of the contract through issue of Letter of Acceptance the Engineer will notify the consultant to commence work as soon as reasonably possible with due expedition and without delay. If the consultant fails to commence works from the date of issue of Notice to Commence Work, that will constitute a breach of contract and in that case the Employer will have right to annul the contract with forfeiture of Performance Security and if the same is not deposited forfeiture of Bid Security.



**VOL. I - SECTION 3:**  
**SECTION 3A FORM OF BID**  
**SECTION 3B FORM OF AGREEMENT**  
**SECTION 3C FORM OF BANK GUARANTEE**  
**FOR PERFORMANCE SECURITY**  
**SECTION 3D UNDERTAKING FOR NOT BLACKLISTED**  
**SECTION 3E UNDERTAKING FOR TECHNICAL**  
**MANPOWER DEPLOYMENT**  
**SECTION 3F C.V. FOR KEY TECHNICAL PERSONNEL**  
**SECTION 3G FORM OF BID SECURITY**  
**(BANK GUARANTEE)**

**VOL. I SECTION 3A.**

**FORM OF BID**

**Name of Contract:** Consultancy Services for Preparation of Detailed Project Report (DPR) incorporating Detailed Engineering Design, working drawings and Tender Documents including tender drawings, tender BOQ etc. for 'Construction of R.C.C Bridge over River Kalnagini at Ghatihara under Kakdwip Block in the district of South 24 Paraganas.

To

The Vice Chairman,  
Hooghly River Bridge Commissioners,  
Munshi Prem Chand Sarani,  
St George's Gate Road,  
Kolkata – 700 021  
West Bengal, India

Gentlemen,

1. In accordance with the Conditions of Contract and Specifications furnished by HRBC and drawings as furnished by HRBC, and Addenda for execution of the above named works, we the undersigned offer to carry out the Consultancy Services for Preparation of Detailed Project Report with Engineering Design and Drawings etc., as per sub clause 1.2 of Instruction to Bidder, Vol 1, Section 2, for the amount of (insert amount first in numbers and then in words) .....  
.....  
quoted by us in the Financial Offer as prescribed by HRBC in accordance with the said Conditions and other bid documents.
2. We undertake, if our Bid is accepted, to commence the Works as soon as possible after the receipt of the notice to commence, and to complete the whole of the Works comprised in the Contract within the time stated in the Bid.
3. We agree to abide by this Bid until ....., 2014 and it shall remain binding upon us and may be accepted at any time before the expiration of that date.
4. Unless and until a formal Agreement is prepared and executed, this Bid, together with your written acceptance thereof, shall constitute a binding Contract between us.

*Contd...*

**Bidder's Signature and Stamp**

5. Deleted.

6. We understand that you are not bound to accept the lowest or any bid you may receive.

Dated this ..... day of ....., 2014

Signature..... in the capacity of .....  
..... duly authorized to sign bids for and on behalf  
of .....  
(in block letters or typed)

Address: .....  
.....

Witness: .....

Address: .....  
.....

Occupation: .....

**VOL. I SECTION 3B.**  
**FORM OF AGREEMENT**

This CONTRACT ( hereinafter called the "Contract" ) is made the \_\_\_\_\_ day of the month of \_\_\_\_\_, 2014 between, on the one hand, The Vice Chairman, Hooghly River Bridge Commissioners, St George's Gate Road, Kolkata-700 021 ( hereinafter called the "Client" ) and, on the other hand, \_\_\_\_\_ ( hereinafter called the "Consultants" )

**WHEREAS**

- (A) the Client has requested the Consultants to provide certain consulting services as defined in the General Conditions attached to this Contract ( hereinafter called the "Services" );
- (B) the Consultants, having represented to the Client that they have the required professional skills, personnel and technical resources, have agreed to provide the Services on the terms and conditions set forth in this Contract;

NOW THEREFORE the parties hereto hereby agree as follows:

- 1. The following documents attached hereto shall be deemed to form an integral part of this Contract:
  - a) The Agreement
  - b) Letter of Acceptance
  - c) Addenda to the Tender Document, if any
  - d) Form of Bid duly filled up
  - e) Instructions to Bidder
  - f) The General Conditions of Contract
  - g) Financial Offer with Payment Schedule
  - h) Drawing
  - i) Notice Inviting Request For Proposal
  - j) Other Documents as agreed upon
- 2. The mutual rights and obligations of the Client and the Consultants shall be as set forth in the Contract; in particular:
  - (a) the Consultants shall carry out the Services in accordance with the provisions of the Contract, and
  - (b) the Client shall make payments to the Consultants in accordance with the provisions of the Contract.

IN WITNESS WHEREOF, the Parties hereto have caused this Contract to be signed in their respective names as of the day and year first above written.

**FOR AND ON BEHALF OF**  
**[CLIENT]**

By \_\_\_\_\_  
**Authorized Representative**

**Witness 1 :**

**FOR AND ON BEHALF OF**  
**[CONSULTANTS]**

By \_\_\_\_\_  
**Authorized Representative**

**Witness 2:**

**Bidder's Signature and Stamp**

**VOL. I SECTION 3C.**

**FORM OF BANK GUARANTEE FOR PERFORMANCE SECURITY**

WHEREAS ..... (Name of Bidder) (hereinafter called "the Consultant") has submitted his bid dated ..... (Date) for "Consultancy Services for Preparation of Detailed Project Report (DPR) incorporating Detailed Engineering Design, working drawings and Tender Documents including tender drawings, tender BOQ etc. for 'Construction of R.C.C Bridge over River Kalnagini at Ghatihara under Kakdwip Block in the district of South 24 Paraganas'" (herein called "the Bid") by "Hooghly River Bridge Commissioners", HRBC Bhawan, St. Georges Gate Road, (Munshi Prem Chand Sarani), Kolkata – 700 021 (hereinafter called the employer which expression shall unless repugnant to or inconsistent with the context mean and include its successors and assigns).

KNOW ALL MEN by these presents that, We, ..... (Name of Bank) having its registered office at ..... (hereinafter called "the Bank") are bound unto ..... (Name of Employer) (hereinafter called "the Employer") in the sum of Rs. .... (Amount of Guarantee) for which the payment well and truly to be made to the said Employer the Bank binds himself, his successors and assigns by these presents.

Sealed with the Common Seal of the said Bank this ..... day of ..... 2014.

THE CONDITIONS of this obligation are:

1. If the bidder having been notified of the acceptance of his Bid by the Employer during his period of validity:
  - (a) fails or refuses to execute the Form of Agreement in accordance with the Information to Consultancy Firm.
  - (b) fails or refuses to furnish the performance security in accordance with the Instruction to Bidders,

Or

2. If the bidder fails or refuses to execute the assignment as specified in the contract.

We undertake to pay to the Employer up to the above amount upon receipt of his first written demand, without the Employer having to substantiate his demand, provided that in his demand the Employer will note that the amount claimed by him is due to him owing to the occurrence of one or both of the two conditions, specifying the occurrence condition or conditions.

This Guarantee will remain in force upto ..... or as it may be extended by the Employer, notice of which extension(s) to the Bank is hereby waived. Any demand in respect of this Guarantee should reach the Bank not later than the above date.

NOTWITHSTANDING anything contained hereinabove,

- (i) Our liability under this Bank Guarantee shall not exceed Rs.....  
(Rupees ..... only)
- (ii) This Bank Guarantee shall be valid upto ..... and
- (iii) We are liable to pay the Bank Guarantee amount or any part thereof under this Bank Guarantee only and only if you serve upon us a written claim or demand on or before .....

DATE.....  
.....  
(SIGNATURE OF THE BANK)

WITNESS .....  
.....  
(BANK SEAL)

.....  
(Signature, Name and Address)

**Bidder's Signature and Stamp**

**VOL. I SECTION 3D.**

**UNDERTAKING FOR NOT BLACKLISTED**

We do hereby undertake that we have not been blacklisted or deregistered by any central/state government department or public sector undertaking and also that none of our work was rescinded by the client after award of contract during last 5 years.

.....  
STAMP & SIGNATURE OF AUTHORIZED SIGNATORY

- NOTE:**
1. In case of JV/Consortium, the undertaking shall be submitted by each member of the JV/Consortium.
  2. The undertaking shall be signed by authorized signatory of the tenderer or constituent member in case of JV/Consortium.

**VOL. I SECTION 3E.**

**UNDERTAKING FOR TECHNICAL MANPOWER DEPLOYMENT**

I ..... (Name and designation) appointed as the attorney/authorized signatory of the Consultant (including its constituents), M/s. ....  
..... (hereinafter called the Consultant) for the purpose of the Bid for the work of '*Consultancy Services for Preparation of Detailed Project Report (DPR) incorporating Detailed Engineering Design, working drawings and Tender Documents including tender drawings, tender BOQ etc. for 'Construction of R.C.C Bridge over River Kalnagini at Ghatihara under Kakdwip Block in the district of South 24 Paraganas'* do hereby solemnly affirm and state on behalf of the Consultant including its constituents as under:

1. We undertake that we will deploy the following key technical personnel, as given in enclosed sheet for carrying out the consultancy services in connection with the two projects.
2. We undertake to deploy non-technical manpower and provide adequate design and drafting facilities including software.

Enclosures: Sheet showing details of key technical personnel.

.....  
**SEAL AND SIGNATURE OF  
THE CONSULTANT**

**VOL. I SECTION 3E (CONTD.)**

***Name of Work : Consultancy Services for Preparation of Detailed Project Report (DPR) incorporating Detailed Engineering Design, working drawings and Tender Documents including tender drawings, tender BOQ etc. for 'Construction of R.C.C Bridge over River Kalnagini at Ghatihara under Kakdwip Block in the district of South 24 Paraganas.***

**DETAILS OF KEY TECHNICAL PERSONNEL**

*(Enclosed sheet of Form 3E)*

<b>Name of the Firm:</b>				
<b>Sl. No.</b>	<b>Name of the personnel</b>	<b>Qualifications</b>	<b>Experience in similar kind of work (in years)</b>	<b>Assigned for the proposed work (full time/part time)</b>



**VOL. I SECTION 3F.**

**CURRICULUM VITAE (CV) FOR KEY TECHNICAL PERSONNEL**

- 1) **Proposed Position** [*Only one candidate shall be nominated for each position*]: \_\_\_\_\_
- 2) **Name of Firm** [*Insert Name of firm proposing the staff*]: \_\_\_\_\_  
\_\_\_\_\_
- 3) **Name of Staff** [*Insert full name*]: \_\_\_\_\_
- 4) **Date of Birth**: \_\_\_\_\_ **Nationality**: \_\_\_\_\_
- 5) **Education** [*Indicate college/University and other specialized education of staff member, giving names of institutions, degrees obtained and dates of obtainment*]: \_\_\_\_\_  
\_\_\_\_\_
- 6) **Membership of Professional Association**: \_\_\_\_\_
- 7) **Other Training** [*Indicate significant training since degrees under 5 – Education obtained*]: \_\_\_\_\_  
\_\_\_\_\_
- 8) **Countries of Work Experience** [*List countries where staff has worked in the last ten years*]: \_\_\_\_\_  
\_\_\_\_\_
- 9) **Languages** [*For each language indicate proficiency: good, fair or poor in speaking, reading and writing*]: \_\_\_\_\_  
\_\_\_\_\_
- 10) **Employment Record** [*Starting with present position, list in reverse order every employment held by staff member since graduation, giving for each employment (see format here below): dates of employment, name of employing organization, positions held*]:

From [Year] \_\_\_\_\_ To [Year] \_\_\_\_\_

Employer: \_\_\_\_\_

Position held: \_\_\_\_\_

**Bidder's Signature and Stamp**

<p>11) <b>Detailed Tasks Assigned</b> [List all tasks to be performed under this assignment]</p>	<p>12) <b>Work undertaken that best Illustrates Capability to handle the Tasks Assigned</b></p> <p><i>[Among the assignment in which the staff has been involved, indicate the following information for those assignment that best illustrate staff capability to handle the tasks listed under point 11]</i></p> <p>Name of assignment of project: _____</p> <p>Year: _____</p> <p>Location: _____</p> <p>Client: _____</p> <p>Main project features: _____</p> <p>Positions held: _____</p> <p>Activities performed: _____</p>
--	---

13) **Certification:**

I, the undersigned, certify that to the best of my knowledge and belief, this CV correctly describes myself, my qualifications and my experience. I understand that any willful misstatement described herein may lead to my disqualification or dismissal, if engaged.

\_\_\_\_\_  
*[Signature of staff member]*

Date: \_\_\_\_\_  
*[Day/Month/Year]*

\_\_\_\_\_  
*Signature of the Bidder*

**Vol. I Section 3 G - FORM OF BID SECURITY (BANK GUARANTEE)**

WHEREAS, (name of bidder) \_\_\_\_\_

(hereinafter called "the Bidder") has submitted his Bid dated (date) \_\_\_\_\_ for the execution of "Consultancy Services for Preparation of Detailed Project Report (DPR) incorporating Detailed Engineering Design, working drawings and Tender Documents including tender drawings, tender BOQ etc. for 'Construction of R.C.C Bridge over River Kalnagini at Ghatihara under Kakdwip Block in the district of South 24 Paraganas'" (hereinafter called "the Bid").

KNOW ALL PEOPLE by these present that we (name of Bank) \_\_\_\_\_ of registered office at \_\_\_\_\_ (hereinafter called "the Bank") are bound unto \_\_\_\_\_ (hereinafter called "the Employer") in the sum of \_\_\_\_\_ for which payment well and truly to be made to the said Employer, the Bank binds himself, his successors, and assigns by these presents.

SEALED with the Common Seal of the said Bank this \_\_\_\_\_ day of \_\_\_\_\_ 201\_\_\_\_\_

THE CONDITIONS of this obligation are:-

- (1) if the Bidder withdraws his Bid during the period of Bid validity specified in the Form of Bid; or
- (2) if the Bidder refuses to accept the correction of errors in his Bid; or
- (3) if the Bidder, having been notified of the acceptance of his Bid by the Employer during the period of Bid validity;
  - (a) fails or refuses to execute the Form of Agreement in accordance with the Instructions to Bidders, if required; or
  - (b) fails or refuses to furnish the Performance Security, in accordance with the Instruction to Bidders;

We undertake to pay to the Employer up to the above amount upon receipt of his first written demand, without the Employer having to substantiate his demand, provided that in his demand the Employer will note that the amount claimed by him is due to him owing, to the occurrence of one or both of the two conditions, specifying the occurred condition or conditions.

This Guarantee will remain in force up to and including the date 28 days after the date of expiration of the Bid Validity as stated in the Instructions to Bidders, or as it may be extended by the Employer, notice of which extension(s) to the Bank is hereby waived. Any demand in respect of this Guarantee should reach the Bank not later than the above date.

SIGNATURE OF THE BANK \_\_\_\_\_  
NAME \_\_\_\_\_  
DESIGNATION \_\_\_\_\_  
DATE \_\_\_\_\_

SEAL \_\_\_\_\_

SIGNATURE OF WITNESS \_\_\_\_\_  
NAME \_\_\_\_\_  
ADDRESS \_\_\_\_\_  
\_\_\_\_\_  
\_\_\_\_\_

The bidder should insert the amount of the guarantee in words and figures. This figure should be the same as shown in Clause 15.1 of Instruction to Bidder.

**Bidder's Signature and Stamp**

**VOL. I - SECTION 4**  
**GENERAL CONDITIONS OF CONTRACT**

## **GENERAL CONDITIONS OF CONTRACT**

### **1. GENERAL PROVISIONS**

#### **1.1 Definitions**

Unless to context otherwise requires, the following terms whenever used in this Contract have the following meanings:

- (a) **“Applicable Law”** means the laws and any other instruments having the force of law in India , as they may be issued and in force from time to time;
- (b) **“Contract”** means this Contract between the Client and the Consultants;
- (c) **“Effective Date”** means the date on which this Contract comes into force and effect pursuant to Clause 2.1 hereof ;
- (d) **“Government”** means the Government of the Client
- (e) **“Personnel”** means persons hired by the Consultants or by any Sub-consultant as employees and assigned to the performance of the Services of any part thereof;
- (f) **“Party”** means the Client or the Consultants, as may the case may be;
- (g) **“Project”** means the “Consultancy Services for Preparation of Detailed Project Report (DPR) incorporating Detailed Engineering Design, working drawings and Tender Documents including tender drawings, tender BOQ etc. for Construction of R.C.C Bridge over River Kalnagini at Ghatihara under Kakdwip Block in the district of South 24 Paraganas”.
- (h) **“Services”** means the work to be performed by the Consultants pursuant to this Contract for the purpose of the Project, as described in Scope of Bid in Clause 1;
- (i) The term **“Client”** means Hooghly River Bridge Commissioners (HRBC);
- (j) The term **“Employer”** shall mean the Vice Chairman, HRBC and include his successor and assign;
- (k) The term **“Engineer”** means the Chief Project Manager, HRBC appointed by the Employer to act as Engineer for the purposes of the Contract ;
- (l) The term **“Engineer’s Representative/Assistant”** means a person appointed from time to time by the Engineer who will be responsible to the engineer and shall carry out such duties and exercise such authority as may be delegated to him by the engineer.
- (m) Any communication given by the engineer’s representative/assistant to the contractor shall have the same effect as though it had been given by the engineer. If the contractor questions any communication of the engineer’s representative/assistant he may refer the matter to the engineer who shall confirm, reverse or vary the contents of such communications. Successor and assign.

## 1.2 Relation between the Parties

Nothing contained herein shall be construed as establishing a relation of master and servant or of agent and principal as between the Client and the Consultants. The Consultants, subject to this Contract, have complete charge of Personnel performing the Services and shall be fully responsible for the Services performed by them or on their behalf hereunder.

## 1.3 Law Governing Contract

This Contract, its meaning and interpretation, the relation between the Parties and settlement of disputes through arbitration shall be governed by the law in force in West Bengal, India, within the jurisdiction of the High Court, Kolkata.

## 1.4 Language

This Contract has been executed in the English language, which shall be the binding and controlling language for all matters relating to the meaning or interpretation of this Contract.

## 1.5 Headings

The headings shall not limit, alter or affect the meaning of this Contract.

## 1.6 Notices

- 1.6.1 Any notice, request or consent required or permitted to be given or made pursuant to this Contract shall be in writing. Any such notice, request or consent shall be deemed to have been given or made when delivered in person to an authorized representative of the Party to whom the communication is addressed, or when sent by registered mail, telex, telegram or facsimile to such Party at the following address:

For the Client .....

For the Consultants .....

- 1.6.2 Notice will be deemed to be effective as follows :

- (a) in the case of personal delivery or registered mail, on delivery
- (b) in the case of facsimiles, forty eight (48) hours following confirmed transmission
- (c) in the case of e-mail, twenty four (24) hours following confirmed transmission

- 1.6.3 A Party may change its address for notice hereunder by giving the other Party notice of such change pursuant to this Clause.

## **1.7 Location**

The Services shall be performed at such locations as are specified in Clause 1 of Instructions to Bidders, Vol. I, Section 2.

## **1.8 Authorized Representatives**

Any action required or permitted to be taken, and any document required or permitted to be executed under this Contract, may be taken or executed:

- (i) on behalf of the Client by the Vice Chairman, HRBC or his designated representatives;
- (ii) on behalf of the Consultants ..... or his designated representatives.

## **1.9 Taxes and Duties**

The consultant shall pay their own taxes of all kinds including corporate income taxes and personnel income taxes, duties, fees, levies and other in connection with providing the services under this contract.

## **2. COMMENCEMENT, COMPLETION, MODIFICATION AND TERMINATION OF CONTRACT**

### **2.1 Effectiveness of Contract**

This Contract shall come into force and effect on the date (the "Effective Date") of the Client's notice to the Consultants instructing to begin carrying out the Services (the "Notice to Commence").

### **2.2 Expiration of Contract**

Unless terminated earlier pursuant to Clause 2.6 hereof this Contract shall terminate when, pursuant to the provisions hereof, the Services have been completed and the payments have been made.

### **2.3 Modification**

Modification of the terms and conditions of this Contract, including any modification of the scope of the Services, may only be made by written agreement between the Parties.

### **2.4 Force Majeure**

#### **2.4.1 Definition**

- (a) For the purpose of this Contract, "Force Majeure" means an event which is beyond the reasonable control of a Party, and which makes a Party's performance of its obligations hereunder impossible or so impractical as reasonably to be considered impossible in the circumstances, and includes, but is not limited to, war, riots, civil disorder, earthquake, fire, explosion, storm, flood or other adverse weather conditions, strikes, lockout or other industrial action (except where such strikes, lockouts or other industrial action are within the power of the Party invoking Force Majeure to prevent), confiscation or any other action by government agencies.

- (b) Force Majeure shall not include (i) any event which is caused by the negligence or intentional action of Party or such Party's sub-consultants or agent or employees, nor (ii) any event which a diligent Party could reasonably have been expected to both (A) take into account at the time of the conclusion of this Contract and (B) avoid or overcome in the carrying out of its obligations hereunder.
- (c) Force Majeure shall not include insufficiency of funds or failure to make any payment required hereunder.

#### **2.4.2 No Breach of Contract**

The failure of a Party to fulfill any of its obligations hereunder shall not be considered to be a breach of, or default under, this Contract insofar as such inability arises from an event of Force Majeure, provided that the Party affected by such an event has taken all reasonable precautions, due care and reasonable alternative measures, all with the objective of carrying out the terms and conditions of this Contract.

#### **2.4.3. Measure to be Taken**

- (a) A Party affected by an event of Force Majeure shall take all reasonable measures to remove such Party's inability to fulfill its obligations hereunder with a minimum of delay.
- (b) A Party affected by an event of Force Majeure shall notify the other Party of such event as soon as possible, and in any event not later than fourteen (14) days following the occurrence of such event, providing evidence of the nature and cause of such event, and shall similarly give notice of the restoration of normal conditions as soon as possible.
- (c) The Parties shall take all reasonable measure to minimize the consequences of any event of Force Majeure.

#### **2.4.3 Extension of Time**

Any period within which a Party shall, pursuant to this Contract, complete any action or task, shall be extended for a period equal to the time during which such Party was unable to perform such action as a result of Force Majeure.

#### **2.4.5 Payments**

For reactivating the Services after the end of Force Majeure no additional payment will be made to the consultant unless mutually agreed by both parties.

#### **2.4.6 Consultation**

Not later than thirty (30) days after the Consultants, as the result of an event of Force Majeure, have become unable to perform a substantial portion of the Services the Parties shall consult with each other with a view to agreeing on appropriate measures to be taken in the circumstances.



## **2.5 Suspension**

The Client may, by written notice of suspension to the Consultants, suspend all payments to the Consultants hereunder if the Consultants fail to perform any of their obligations under this Contract, including the carrying out of the Service provided that such notice of suspension (i) shall specify the nature of the failure and (ii) shall request the Consultants to remedy such failure within a period not exceeding thirty (30) days after receipt by the Consultants of Such notice of suspension.

## **2.6 Termination**

### **2.6.1 By the Client**

The Client may, by not less than thirty (30) days' written notice of termination of the Consultants (except in the event listed in paragraph (f) below, for which there shall be a written notice of not less than sixty (60) days), such notice to be given after the occurrence of any of the events specified paragraph (a) through (f) of this Clause 2.6.1, terminate this contract

- (a) if the consultants fail to remedy a failure in the performance of their obligations hereunder, as specified in a notice of suspension pursuant to Clause 2.5 hereinabove, within thirty (30) days of receipt of such notice of suspension or within such further period as the Client may have subsequently approved in writing;
- (b) if the Consultants become insolvent or bankrupt or enter into any agreement with their creditors for relief of debt or take advantage of any law for the benefit of debtors or go into liquidation or receivership whether compulsory or voluntary;
- (c) if the Consultants fail to comply with any final decision reached as a result of arbitration proceedings pursuant to Clause 8 hereof;
- (d) if the Consultants submit to the Client a statement which has material effect on the rights, obligations or interests of the Client and which the Consultant know to be false;
- (e) if, as the result of Force Majeure, the Consultants are unable to perform a material portion of the Services for a period of not less than sixty (60) days; or
- (f) if the Client, in its sole discretion and for any reason whatsoever, decides to terminate this Contract.

### **2.6.2 By the Consultants**

The Consultants may, by not less than thirty (30) days' written notice to the Client, such notice to be given after the occurrence of any of the events specified in paragraph (a) through (d) of this Clause 2.6.2, terminate this Contract;

- (a) if the Client fails to pay any money due to the Consultants pursuant to this Contract and not subject to dispute pursuant to Clause 8 hereof within forty-five (45) days after receiving written notice from the Consultants that such payment is overdue;

- (b) if the Client is in material breach of its obligations pursuant to this Contract and has not remedied the same within forty-five (45) days ( or such longer period as the Consultants may have subsequently approved in writing ) following the receipt by the Client of the Consultants' notice specifying such breach;
- (c) if, as the result of Force Majeure, the Consultants are unable to perform a material portion of the Services for a period of not less than sixty (60) days ; or
- (d) if the Client fails to comply with any final decision reached as a result of arbitration pursuant to Clause 8 hereof.

### **2.6.3 Cessation of Rights and Obligations**

Upon termination of this Contract pursuant to Clause 2.6 hereof, or upon expiration of this Contract pursuant to Clause 2.2 hereof, all rights and obligations of the Parties hereunder shall cease, except (i) such rights and obligations as may have accrued on the date of termination or expiration, (ii) the obligation of confidentiality set forth in Clause 3.3 hereof, (iii) the Consultants' obligation to permit inspection, copying and auditing of their account and records set forth in Clause 3.7 (ii) hereof, and (iv) any right which a Party may have under the Applicable Law.

### **2.6.4. Cessation of Service**

Upon termination of this Contract pursuant to Clauses 2.6.1 or 2.6.2 hereof, the Client shall make the following payments to the Consultants:

- (i) remuneration pursuant to Clause 6.1 hereof of Services Satisfactory performed prior to the effective date of termination.

### **2.6.5. Payment upon Termination**

Upon termination of this Contract pursuant to Clause 2.6.1. or 2.6.2 hereof, the Client shall make the following payments to the Consultants:

- (i) amount for items of service which have been executed prior to the date of termination but payment for the same not yet made to the consultant.
- (ii) a proportionate sum being the amount of any expenditure reasonably incurred by the Consultant for the Service partially performed.

### **2.6.6 Disputes about Events of Termination**

If either Party disputes whether an event specified in paragraphs (a) through (e) of Clause 2.6.1. or in Clause 2.6.2. hereof has occurred, such Party may, within forty-five (45) days after receipt of notice of termination from the other Party, refer the matter to arbitration pursuant to Clause 8 thereof.

### **3. OBLIGATIONS OF THE CONSULTANTS**

#### **3.1 General**

##### **3.1.1 Standard of Performance**

The Consultants shall perform the Services and carry out their obligations there under with all due diligence, efficiency and economy, in accordance with generally accepted techniques and practices used in the construction industry and with professional engineering and consulting standards recognized by international professional bodies, and shall observe sound management and technical and engineering practices, and employ appropriate advanced technology and safe and effective equipment, machinery, materials and methods. The Consultants shall always, act, in respect of any matter relating to this Contract or the Services, as faithful advisers to the Client, and shall at all times support and safeguard the Client's legitimate interests in any dealings with sub-consultants or Third Parties.

##### **3.1.2 Law Governing Services**

The Consultants shall perform the Services in accordance with the Applicable Law and shall take all practicable steps to ensure that any Sub-consultants, as well as Personnel and agents of the Consultants and any Sub-consultants, comply with the Applicable Law.

#### **3.2 Conflict of Interests**

##### **3.2.1 Consultants not to Benefit from Commissions, Discounts, etc.**

The remuneration of the Consultants pursuant to Clause 6 hereof shall constitute the Consultants' sole remuneration in connection with this Contract Services and, subject to Clause 3.2.2 hereof, the Consultants shall not accept for their own benefit any trade commission, discount or similar payment in connection with activities pursuant to this Contract or the Services or in the discharge of their obligations there under, and the Consultants shall use their best efforts to ensure that any Sub-consultants, as well as the Personnel and agents of either of them, similarly shall not receive any such additional remuneration.

##### **3.2.2 Procurement Rules of Funding Agencies**

If the Consultants, as part of the Services, have the responsibility of advising the Client on the procurement of goods, works or services, the Consultants shall at all times exercise such responsibility in the best interest of the Client.

##### **3.2.3 Consultants and Affiliates not to be otherwise Interest in Project**

The Consultants agree that, during the term of this Contract and after its termination, the Consultant and any entity affiliated with sub-consultant, shall be disqualified from providing goods, works or service (other than the Services and any continuation thereof) for the project.

### **3.2.4 Prohibition of Conflicting Activities**

Neither the Consultants nor their Sub-consultants nor the Personnel of either of them shall engage, either directly or indirectly, in any business or professional activities which would conflict with the activities assigned to them under this control.

### **3.3 Confidentiality**

The Consultants, their Sub-consultants and the Personnel of either of them shall not, either during the term or within two (2) years after the expiration of this Contract, disclose any proprietary or confidential information relating to the Project, the Services, this Contract of the Client's business or operations without the prior written consent of the Client.

### **3.4 Liability of the Consultants**

The Consultants shall be liable to the Client for the performance of the Services in accordance with the provisions of this Contract and for any loss suffered by the Client as a result of a default of the Consultants in such performance, subject to the following limitations:

- (a) The Consultants shall not be liable for any damage or injury caused by or arising out of the act, neglect, default or omission of any persons other than the Consultants, its Sub-consultants or the Personnel of either of them, and
- (b) The Consultants shall not be liable for any loss or damage caused by or arising out of circumstances over which the Consultants had no control.

### **3.5 Indemnification of the Client by the Consultants**

The Consultants shall keep the Client, both during and after the term of this Contract, fully and effectively indemnified all losses, damage, injuries, deaths, expenses, actions, proceedings, demands, costs and claims, including, but not limited to, legal fees and expenses, suffered by the Client or any Third Party, where such loss, damage, injury or death is the result of a wrongful action, negligence or breach of Contract of the Consultants or their Sub-consultants, or the Personnel or agents of either of them, including the use or violation of any copyright work or literary property or patented invention, article or appliance.

### **3.6 Insurance to be taken by the Consultants**

The Consultants (i) shall take out and maintain, and shall cause any Sub-consultants to take out and maintain, at their ( or the Sub-consultants', as the case may be ) own cost but on terms and conditions approved by the Client, insurance against the risks, and for the coverage, set forth below, and (ii) at the Client's request, shall provide evidence to the Client showing that such insurance has been taken out and maintained and that current premiums thereof have been paid :

- (a) Third Party motor vehicle liability insurance in respect of motor vehicle operated by the Consultants or their Personnel or any Sub-consultants or their Personnel.
- (b) Third party liability insurance
- (c) employee's liability and workers' compensation insurance in respect of the Personnel of the Consultants and of any Sub-consultant, in accordance with the relevant provision of the Applicable Law, as well as, with respect to such Personnel, any such life, health, accident, travel or other insurance as may be appropriate; and
- (d) Insurance against loss of or damage to (i) equipment purchased in whole or in part with funds provided under this Contract, (ii) the Consultants' property used in the performance of the Services, and (iii) any documents prepared by the Consultants in the performance of the Services.

### **3.7 Accounting, Inspection and Auditing**

The Consultants (i) shall keep accurate and systematic accounts and records in respect of the Services hereunder, in accordance with accepted accounting principles and in such form and detail as will clearly identify all relevant time charges and cost, and the bases thereof ( including the bases of the Consultant's representations referred to in Clause 6.3 (b) hereof ), and (ii) shall permit the Client or its designated representative periodically, and up to one year from the from the expiration or termination of this Contract, to inspect the same and make copies thereof as well as to have them audited by auditors appoint by the Client.

### **3.8 Deleted**

### **3.9 Reporting Obligations**

The bidder should submit a statement in separate annexure giving details of various reports, drawings and documents which will be supplied to HRBC in respect of Preliminary Conceptual Scheme as well as Detail Project Report.

### **3.10 Documents prepared by the Consultants to be Property of the Client**

All plans, drawings, specifications, designs, reports and other documents prepared by the Consultants in performing the Services shall become and remain the property of the Client, and the Consultants shall, not later than upon termination or expiration of this Contract, deliver all such documents to the Client, together with a detailed inventory thereof. The Consultants may retain a copy of such documents but shall not use them for purposes unrelated to this Contract without the prior written approval of the Client.

### **3.11 Equipment and Materials furnished by the Client**

Equipment and materials made available to the Consultants by the Client, or purchased by the Consultants with funds provided by the Client, shall be the property of the Client and shall be marked accordingly. Upon termination or expiration of this Contract, the Consultants shall make available to the Client an inventory of such equipment and materials and shall dispose of such equipment and materials in accordance with the Client's instruction.

## **4. CONSULTANTS' PERSONNEL**

### **4.1 General**

The Consultants shall employ and provide such qualified and experienced Personnel as are required to carry out the Services.

### **4.2 Deleted**

### **4.3 Deleted**

### **4.4 Deleted**

## **5. OBLIGATIONS OF THE CLIENT**

### **5.1 Assistance and Exemptions**

The Client shall use its best efforts to ensure to:

- (a) provide the Consultants, Sub-consultants and Personnel with work permits and such other documents as shall be necessary to enable the Consultants, Sub-consultants or Personnel to perform the Services;
- (b) issue to officials, agents and representatives of the Government all such instructions as may be necessary or appropriate for the prompt and effective implementation of the Services.

### **5.2 Access to Land**

The Client warrants that the Consultants shall have, free of charge, unimpeded access to all land in the Government's country in respect of which access is required for the performance of Services. The Client will be responsible for any damage to such land or any property thereon resulting from such access and will indemnify the Consultants and each of the Personnel in respect of liability for any such damage, unless such damage is caused by the default or negligence of the Consultants or any Sub-consultant or the Personnel of either of them.

### **5.3 Services, Facilities and Property of the Client**

The client shall make available to the Consultants and the Personnel, for the purposes of the Services and free of any charge, all available maps, drawings, data and any other information necessary for the services.

### **5.4 Payment**

In consideration of the Services performed by the Consultants under this Contract, the Client shall make to the Consultants such payments and in such manner as is provided by Clause 6 of this Contract.

## **5.5 Indemnification of the Consultants by the Client**

The Client shall keep the Consultants, both during and after the term of this Contract, fully and effectively indemnified against all losses, damage, injuries, death, expenses, actions, proceedings, cost and claims, including, but not limited to, legal fees and expenses suffered by the Consultants or any Third Party where such loss, damage, injury or death is the result of a wrongful action, negligence or breach of contract of the Client or its employees or agents.

## **6. PAYMENTS TO THE CONSULTANTS**

**6.1** Professional fees as quoted by the Consultant finally accepted by the Client will be paid as stated in the Instructions to Bidder as per payment schedule given therein.

**6.2 Deleted**

## **7. FAIRNESS AND GOOD FAITH**

### **7.1 Good Faith**

The Parties undertake to act in good faith with respect to each other's rights under this Contract and to adopt all reasonable measures to ensure the realization of the Objectives of this Contract.

### **7.2 Operation of the Contract**

The Parties recognize that it is impractical in this Contract to provide for every contingency which may arise during the life of the Contract, and the Parties hereby agree that it is their intention that this Contract shall operate fairly as between them, and without detriment to the interest of either of them, and that, if during the term of this Contract either Party believes this Contract is operating unfairly, the Parties will use their best efforts to agree on such action as may be necessary to remove the cause of causes of such unfairness, but no failure to agree on any action pursuant to this Clause shall give rise to a dispute subject to arbitration in accordance with Clause 8 hereof.

## **8. SETTLEMENT OF DISPUTES**

### **8.1 Amicable Settlement**

The parties shall use their best efforts to settle amicably all disputes arising out of or in connection with this contract or the interpretation thereof.

**8.2** Any dispute between the parties as to matters arising pursuant to this contract, which cannot be settled amicably may be referred to arbitration by a sole arbitrator to be appointed by the Vice-Chairman, HRBC. All Arbitral matters and proceeding shall conform with the Arbitration and Conciliation Act, 1996.

## **9. EXTENSION OF TIME**

- 9.1** If the consultant shall desire an extension of time for completion of the work on the grounds of his having been unavoidably hindered in its execution or any other ground he shall apply in writing to the HRBC within seven days of the date of hindrance on account of which he desires such extension as aforesaid.
- 9.2** The HRBC after satisfying itself about the reasonableness of grounds may grant extension of time which shall be final and binding as in his opinion be justified and communicate the same in writing. Wherever such extension of time is granted, it would be without prejudice to the rights of HRBC to take any other action under the provisions of the contract. Any extension of time granted as stated above shall neither entitle the consultant to any claim for increase in their fees nor shall it release him from any of the obligations under the said agreement.

## **10. COMPENSATION FOR DELAY**

- 10.1** The work shall carried out within the stipulated period in continuation with all due diligence, keeping in view the time is the essence of contract.
- 10.2** In the event of consultant failing to comply with the above conditions, the consultant shall pay to the Employer as compensation on account of liquidated damages an amount equal to 1/6% (one sixth percentage) of the value of the total lump sum consultancy fees payable as per terms of contract per week.
- 10.3** However, the total amount of compensation under this provision of the clause shall be limited to max. 10% (ten percent) of the value of the total lump sum consultancy fees payable.
- 10.4** The delay in clients assistance ingrained in the contract will be taken duly into account while recovering any compensation delay in the scale prescribed above.



**VOLUME II**  
**FINANCIAL OFFER**

## FINANCIAL OFFER

Sl. No.	Schedule of Consultancy	Consultancy fees in Rs. (in lump sum) as per Cl. 12 of Instructions to Bidders (To be written both in figures and words)
1	Providing Consultancy Services for Preparation of Detailed Project Report (DPR) incorporating Detailed Engineering Design, working drawings and Tender Documents including tender drawings, tender BOQ etc. for 'Construction of R.C.C Bridge over River Kalnagini at Ghatihara under Kakdwip Block in the district of South 24 Paraganas.	

Note: For the purpose of making interim payments, the following Payment Schedule shall be followed. Total payment at the end of the work shall be limited to the lump sum consultancy fees quoted by the bidder.

.....  
(Signature of Consultant)

**Bidder's Signature and Stamp**

## **PAYMENT SCHEDULE**

<b>Stage</b>	<b>Delivering of Services</b>	<b>PAYMENT %</b>
1	<ul style="list-style-type: none"> <li>• Preparation of alternative proposals for finalization of concept and structural system as detailed in the RFP doc. and submission for approval of the same by the authority.</li> <li>• Preparation and submission of GAD along with Hydrological Report to I &amp; W Dept for vetting as per their rules and after obtaining approval, submission of the approved documents in original to the client.</li> <li>• Preparation and submission of Preliminary Project Report with preliminary project estimate.</li> </ul>	10 % of total fees
2	<ul style="list-style-type: none"> <li>• Preparation and submission of detailed cost estimate including quantity calculation and rate analysis, technical specification, bill of quantities and tender drawings. etc. based on approved drawings.</li> </ul>	20 % of total fees
3	<ul style="list-style-type: none"> <li>• Preparation and submission of substructure drawings with design calculations up to pile cap level with all details after obtaining vetting from the Proof Consultant.</li> </ul>	10 % of total fees
4	<ul style="list-style-type: none"> <li>• Preparation and submission of substructure drawings with design calculations from pile cap level to pier cap/ abutment cap with all details after obtaining vetting from the Proof Consultant.</li> </ul>	10 % of total fees
5	<ul style="list-style-type: none"> <li>• Preparation and submission of superstructure (including viaduct, if any) drawings with design calculations above pier cap/ abutment cap with all details after obtaining vetting from the Proof Consultant.</li> </ul>	30 % of total fees
6	<ul style="list-style-type: none"> <li>• Preparation and submission of Miscellaneous working drawings with design calculations in respect to following works.                             <ol style="list-style-type: none"> <li>1. Bearings</li> <li>2. Expansion Joints</li> <li>3. Approach road</li> <li>4. Parapet, Drainage Spout, Wearing coat, Handrails etc.</li> </ol> </li> </ul>	10 % of total fees
7	<ul style="list-style-type: none"> <li>• Preparation and submission of Detailed Project Report (DPR).</li> </ul>	5 % of total fees
8	<ul style="list-style-type: none"> <li>• On compliance of modifying and revising structural / working drawings or for any other specific requirement relating to services of the consultant.</li> <li>• On completion of the scope of work as provided in the contract to the satisfaction of the client.</li> </ul>	5 % of total fees

**Note:** The stage wise payment schedules stated above may be further split up at the time of signing agreement by consent of both parties to facilitate payment.

**Bidder's Signature and Stamp**

**VOLUME III  
DRAWING**

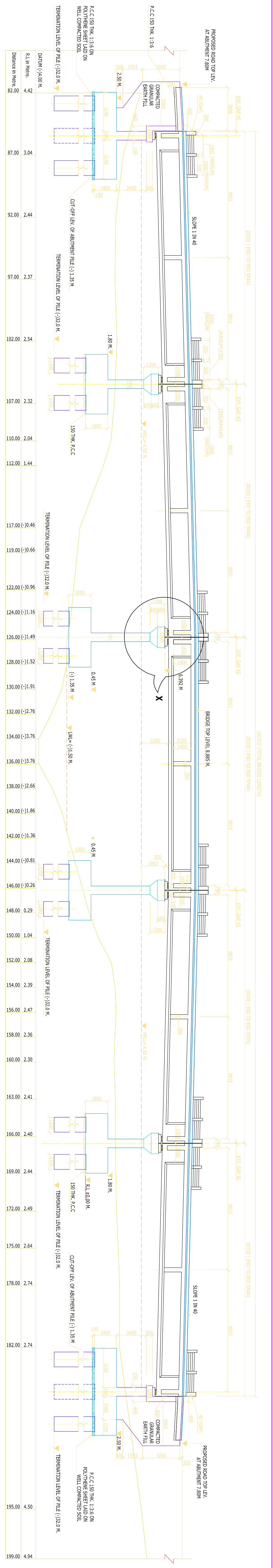

GENERAL ELEVATION  
(SEC. A - A)

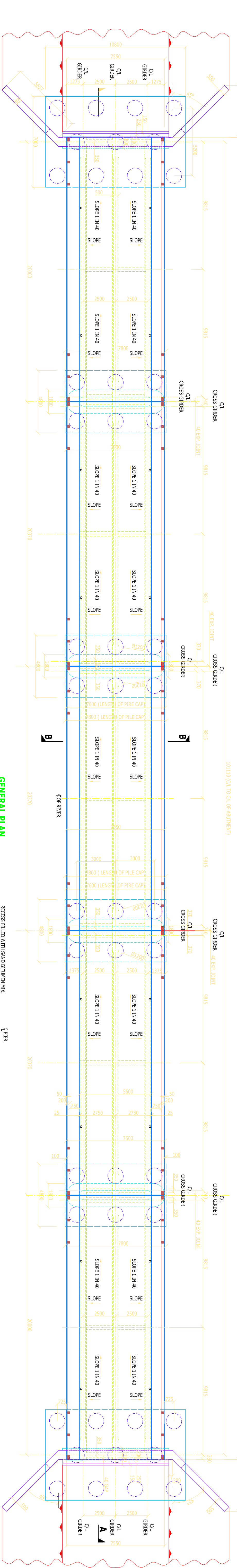

GENERAL PLAN

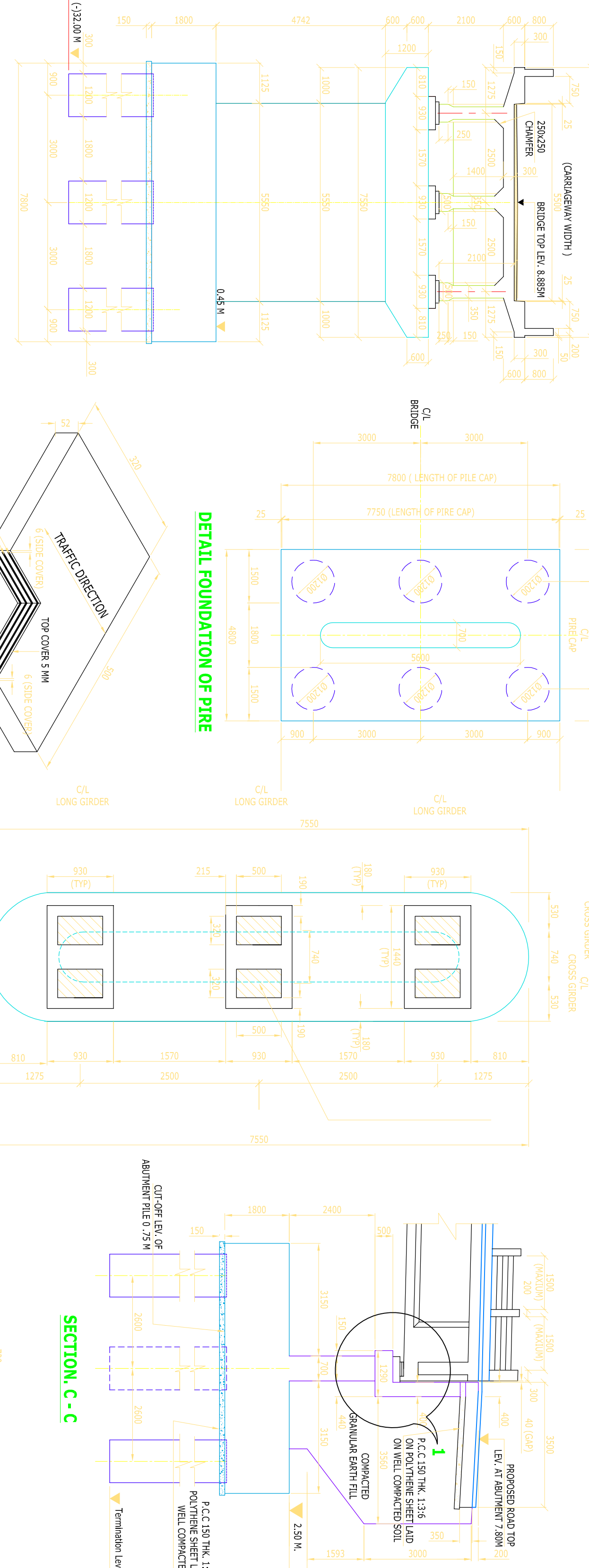

DETAIL FOUNDATION OF PILE

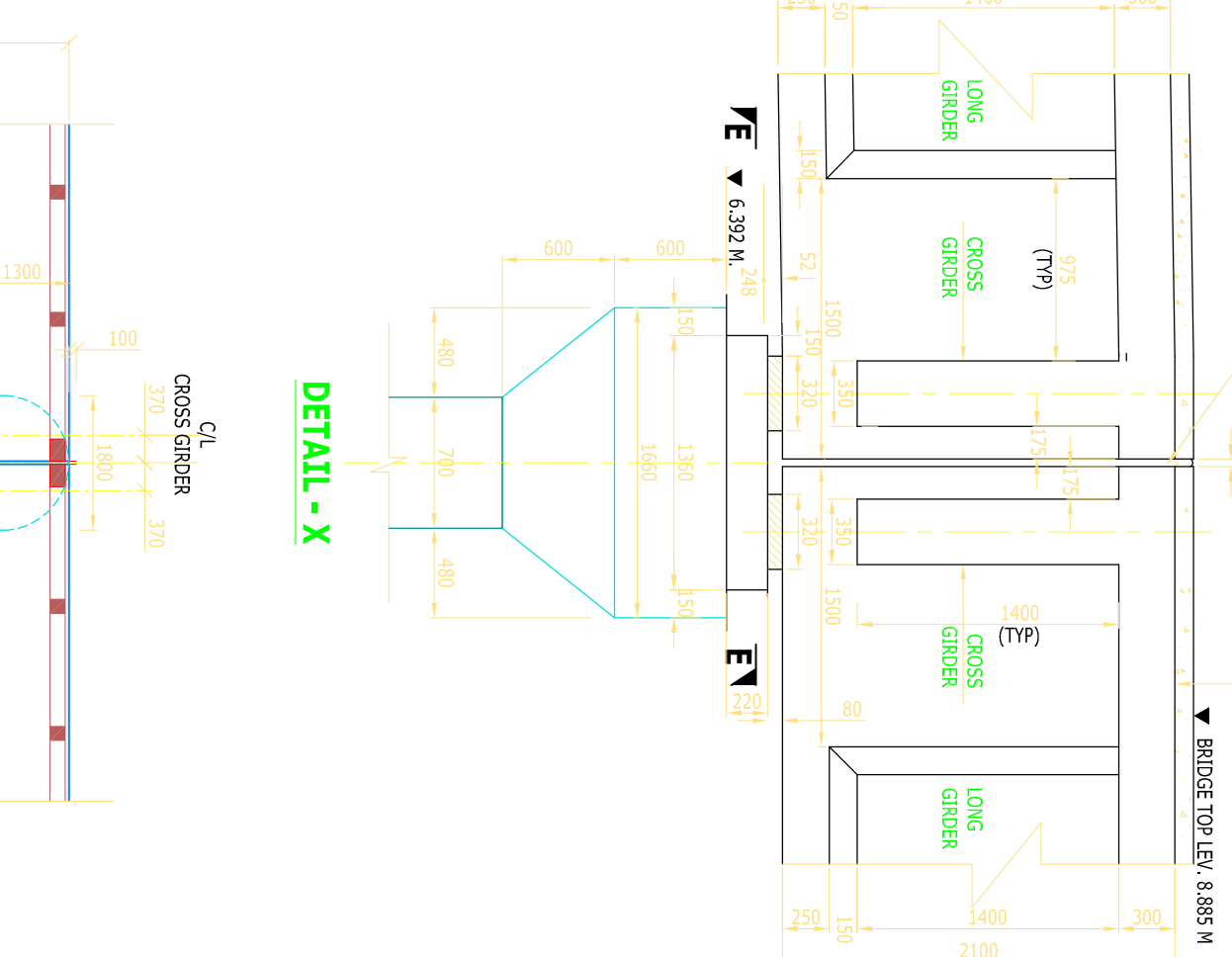

DETAIL - X



SECTION - C - C

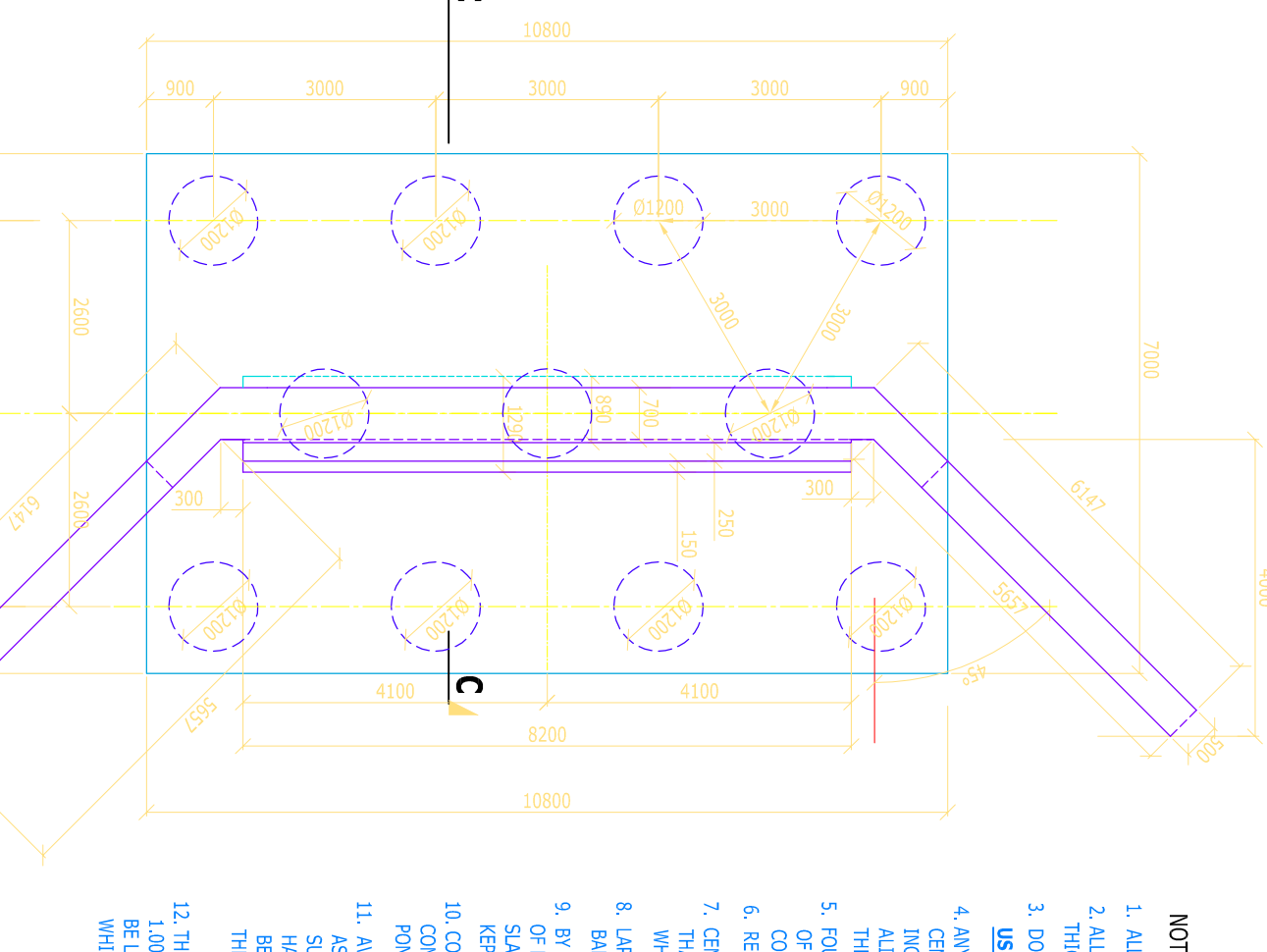

DETAIL FOUNDATION OF ABUTMENT  
FOR TENDER PURPOSE ONLY

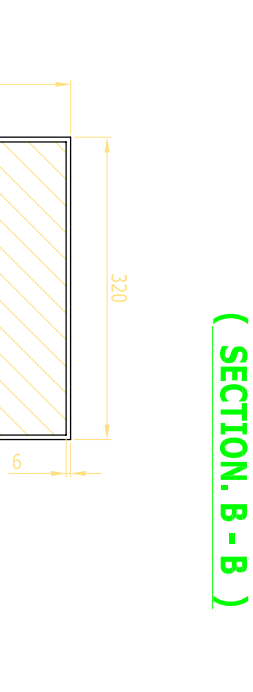

(SECTION - B - B)

ISOMETRIC VIEW AND DETAILS  
OF ELASTOMETRIC BEARING

PIER PILE CAP WITH  
PEDESTAL & BEARING  
(VIEW E - E)

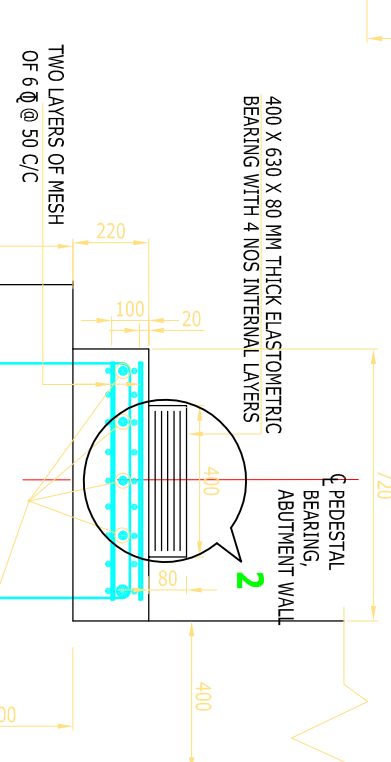

DETAILS '1'



DETAILS '2'

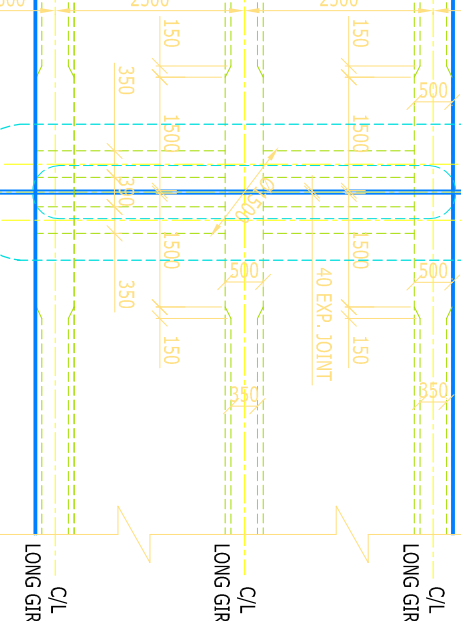

GIRDER ARRANGEMENT

13 ROUTINE TEST BY MAINTENANCE MEN SHOULD BE MADE ON ONE OR TWO PILES WITH A TEST LOAD OF 200 kN WITH MAXIMUM SETTLEMENT OF TEST COLUMN IN POSITION REMAINING NOT EXCEEDING 12 mm. LOAD TEST OVER AT LEAST 30 MINUTES BEFORE THE END OF WORKING HOURS.

14 THE SOIL STRENGTH PARAMETERS ARE TAKEN FROM RECENT SOIL TEST REPORT.

15 LAYOUT OF RAILING POSTS TO BE MADE SUITABLE WITH SPACING MAXIMUM 1800 mm WITH TWO POSTS ON EACH SIDE. SUITABLE SPACING ARE TO BE LEFT ACCORDINGLY WHILE CONCRETING EACH SLAB BY THE DETAIL ENGINEER.

16 AFTER COMPLETION OF DECK SLAB & RENDING OVERHEAD BUILD UP FROM CANAL BED, THE LOCATION OF THIS ROCK BE SUITABLE CHosen BY THE ENGINEER-IN-CHARGE. VIEW HOOK AS DRAWN MAY ALSO LEFT IN SUITABLE LOCATIONS ON THE HORIZONTAL FACES OF CONCRETE BEAM TO START THE POST FOR SHAPING TO CONDUIT Etc.

17 THE EXTENT AND THE RATIO OF REBAR TO APPROACH ROAD PART OF WHICH TO BE MADE ON THE COMPLETED SIDEWALK OF THE ABUTMENT AT TWO ENDS OF THE BRIDGE IS LEFT TO THE DISCRETION OF THE DESIGNER.

- NOTES :-**
- ALL DIMENSIONS IN MM & LEVELS ARE IN METERS / (GTS UNLESS OTHERWISE SPECIFIED).
  - ALL P.C.C WORK IS OF QUADRATIC MIX OF 1:3:6 AND MUST BE UNDERLAIN BY POLYTHENE SHEET OF SUITABLE THICKNESS ON WELL COMPACTED SOIL.
  - DO NOT SCALE ANY DIMENSION IN THE DRAWING.
  - USE OF PLASTER IN ALL CONCRETE WORK IS A MUST.
  - ANY CONCRETE WORK LEFT UNCOMPLETED FOR MORE THAN 30 MINUTES, MUST BE RESTARTED USING A CONTING OF CRUSHED STEEL WIRE NETTING (TYP) FOR LATE ABUTMENT ON THE SURFACE OF THE CONCRETE SO LEFT UNCOMPLETED. THIS SHOULD BE MADE STRICTLY KNOWN TO MAKING OF OTHER WORK IN CONNECTION TO THE CONSTRUCTION OF WHICH 28 DAYS STRENGTH HAS ALREADY BEEN ACHIEVED SPECIALLY ON THE FILL HEAD.
  - FOUNDATIONS ARE OF DOWN CAST - IN - SITU, ROUGH FACES OF PLYS SHALL BE OF CONCRETE WITH CLEAR COVER CONC. ALL OTHER FACE WORKS ARE OF PLYS OR CONCRETE WITH CLEAR COVER CONC. WITH 4% BINDER.
  - CHIENT SHOULD BE OF INDIAN STANDARD MAKE WITH M20 AND FINAL SETTING SHOULD NOT BE LESS THAN 1000°C (1900°F) WITHIN 30 MINUTES RESPECTIVELY AND THERE SHOULD NOT BE ANY FALSE SET WHILE CONCRETING.
  - REINFORCING STEEL SHALL BE OF GRADE IV - 415, WHICH IS AS PER IS: 1786. LAYERS OF INDIAN STANDARD MAKE.
  - CHIENT SHOULD BE OF INDIAN STANDARD MAKE WITH M20 AND FINAL SETTING SHOULD NOT BE LESS THAN 1000°C (1900°F) WITHIN 30 MINUTES RESPECTIVELY AND THERE SHOULD NOT BE ANY FALSE SET WHILE CONCRETING.
  - REINFORCING STEEL SHALL BE OF GRADE IV - 415, WHICH IS AS PER IS: 1786. LAYERS OF INDIAN STANDARD MAKE.
  - CHIENT SHOULD BE OF INDIAN STANDARD MAKE WITH M20 AND FINAL SETTING SHOULD NOT BE LESS THAN 1000°C (1900°F) WITHIN 30 MINUTES RESPECTIVELY AND THERE SHOULD NOT BE ANY FALSE SET WHILE CONCRETING.
  - REINFORCING STEEL SHALL BE OF GRADE IV - 415, WHICH IS AS PER IS: 1786. LAYERS OF INDIAN STANDARD MAKE.
  - CHIENT SHOULD BE OF INDIAN STANDARD MAKE WITH M20 AND FINAL SETTING SHOULD NOT BE LESS THAN 1000°C (1900°F) WITHIN 30 MINUTES RESPECTIVELY AND THERE SHOULD NOT BE ANY FALSE SET WHILE CONCRETING.
  - REINFORCING STEEL SHALL BE OF GRADE IV - 415, WHICH IS AS PER IS: 1786. LAYERS OF INDIAN STANDARD MAKE.
  - CHIENT SHOULD BE OF INDIAN STANDARD MAKE WITH M20 AND FINAL SETTING SHOULD NOT BE LESS THAN 1000°C (1900°F) WITHIN 30 MINUTES RESPECTIVELY AND THERE SHOULD NOT BE ANY FALSE SET WHILE CONCRETING.
  - REINFORCING STEEL SHALL BE OF GRADE IV - 415, WHICH IS AS PER IS: 1786. LAYERS OF INDIAN STANDARD MAKE.
  - CHIENT SHOULD BE OF INDIAN STANDARD MAKE WITH M20 AND FINAL SETTING SHOULD NOT BE LESS THAN 1000°C (1900°F) WITHIN 30 MINUTES RESPECTIVELY AND THERE SHOULD NOT BE ANY FALSE SET WHILE CONCRETING.

PLAN OF ELASTOMETRIC BEARING

INDEX PLAN

## GOVERNMENT OF WEST BENGAL SUNDARBAN DEVELOPMENT BOARD

### PROPOSED DOUBLE LANE R.C.C. BRIDGE OVER WING OF KALINGINI RIVER CHANNEL AT GAUTHARA CONNECTING PRATAPADITYA NAGAR & BABULI G.P OF KAKOPUR D. S & BLOCK - KAKOPUR UNDER KAKOPUR SUB DIVISION OF CIVIL ENGINEERING DIVISION -II-

GENERAL ARRANGEMENT DRAWING

DRG. No.	FILE No.	DD	MM	YY
HEAD D./MAN	DRAWN BY	ASST. ENGINEER	EXE. ENGINEER	SR. ENGINEER
		S.D. CIVIL	S.D. CIVIL	S.D. P.C.
SHEET NO. 1/2				